

PARTS LIST		
ITEM	QTY	PART NUMBER
1	1	Base Stand
2	1	Lower Left Arm
3	1	Lower Right Arm
4	2	Lower Rivet
5	1	Lift Plate
6	1	Upper Left Arm
7	1	Upper Right Arm
8	2	Upper Rivet
9	1	Screw Assembly
10	1	Nut

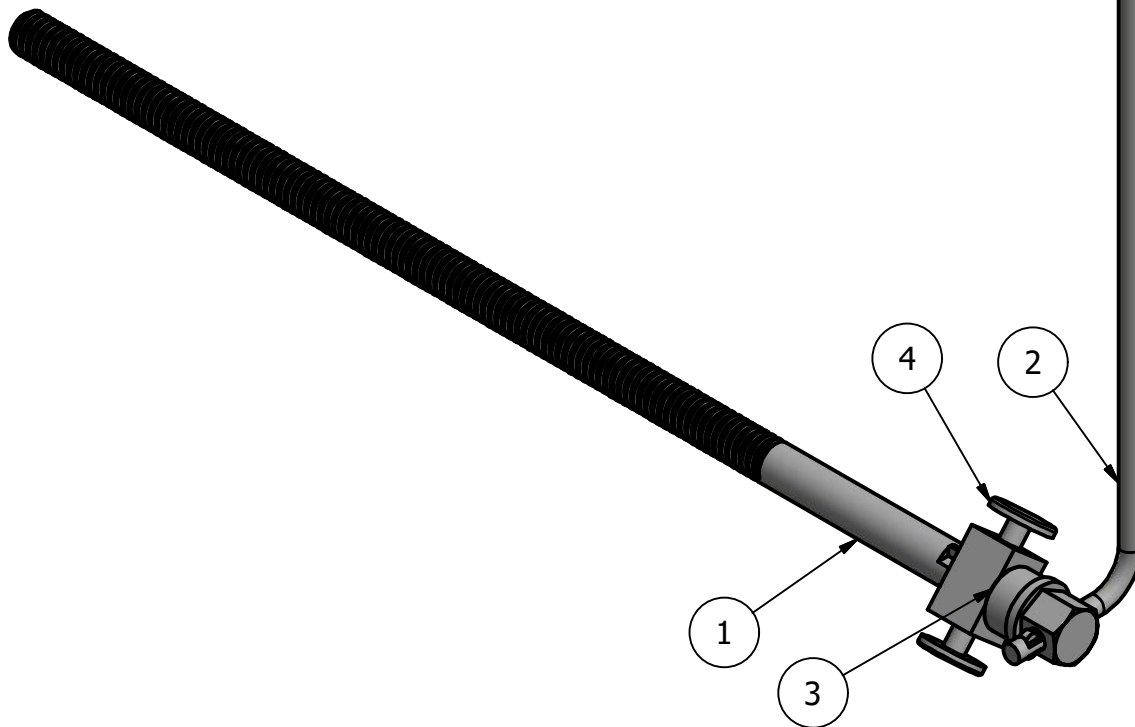

PARTS LIST		
ITEM	QTY	PART NUMBER
1	1	Jack Screw
2	1	Handle
3	1	Screw Clearance Washer
4	1	Screw Clearance Rivet

UNLESS OTHERWISE NOTED
 BREAK ALL SHARP EDGES .015
 STAMP DWG NUMBER ON ALL
 PARTS

TOLERANCE: ANGLES:
 .X ±.015 ±0.5
 .XX ±.010
 .XXX ±.005

DESIGNED	
DETAILED	
TRACED	
CHECKED	
APPROVED	MATHER, JD
ISSUED	

TITLE:
Jack Screw Assembly

SCALE: 1:2	IPT:
COURSE:	SEC: IAM:
DATE: 1/1/2015	IDW: Scissors Jack S2015.idw

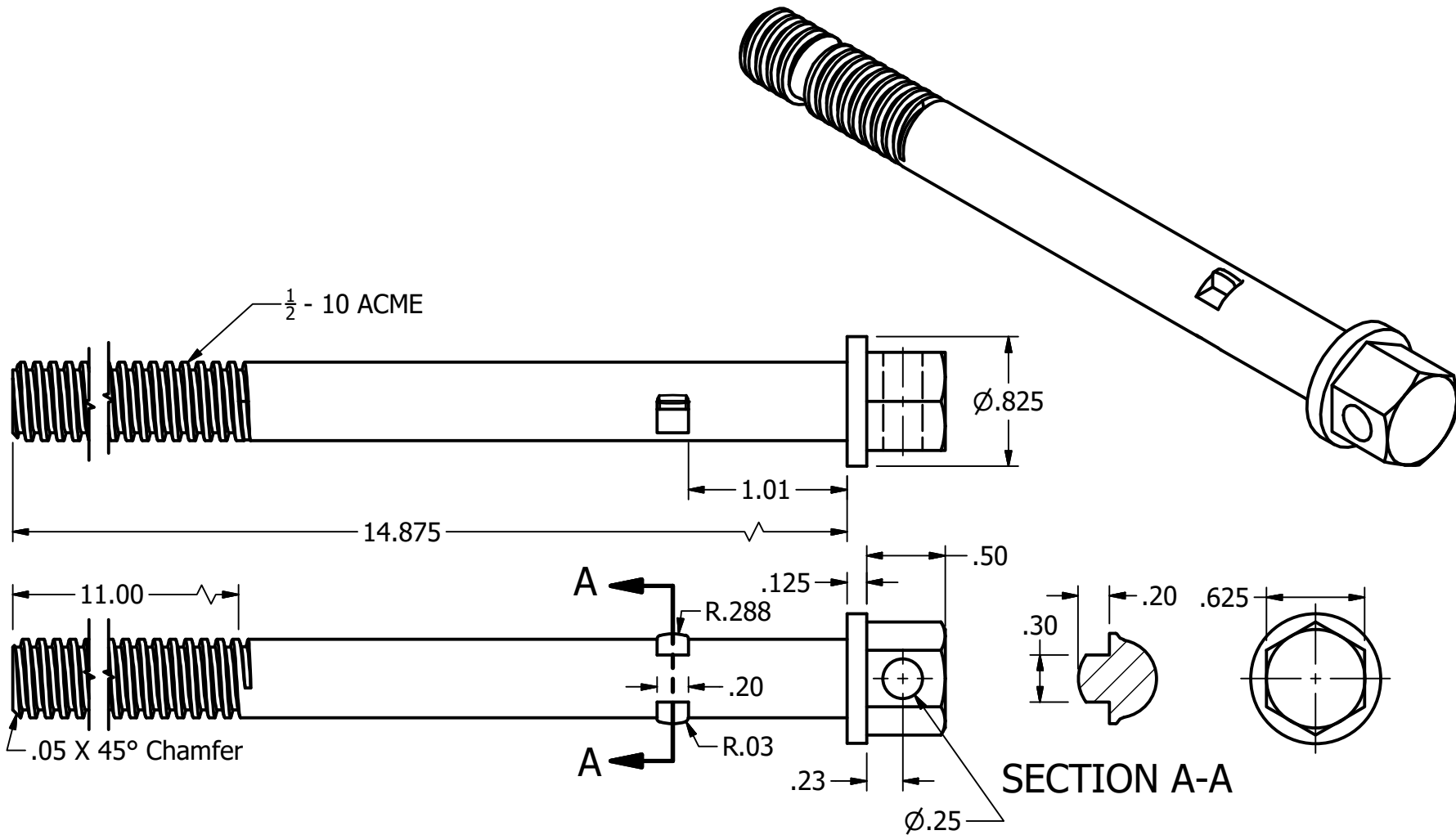

UNLESS OTHERWISE NOTED
 BREAK ALL SHARP EDGES .015
 STAMP DWG NUMBER ON ALL
 PARTS

TOLERANCE: ANGLES:
 .X ±.015 ±0.5
 .XX ±.010
 .XXX ±.005

DESIGNED	
DETAILED	
TRACED	
CHECKED	
APPROVED	MATHER, JD
ISSUED	

TITLE:		Jack Screw	
SCALE:	1:1	IPT:	
COURSE:		SEC:	IAM:
DATE:	1/1/2015	IDW: Scissors Jack S2015.idw	

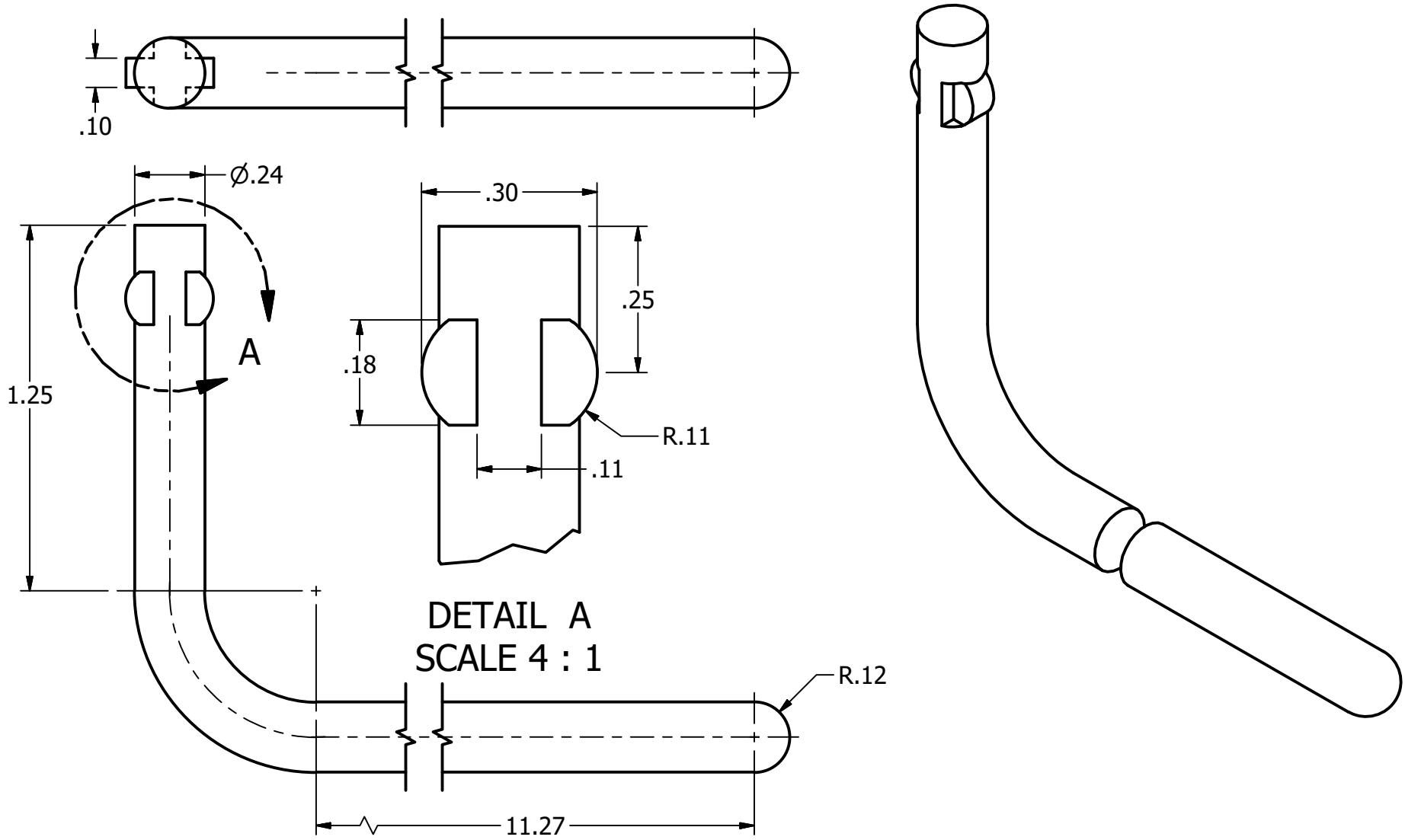

DETAIL A
SCALE 4 : 1

UNLESS OTHERWISE NOTED
 BREAK ALL SHARP EDGES .015
 STAMP DWG NUMBER ON ALL
 PARTS
 TOLERANCE: ANGLES:
 .X ±.015 ±0.5
 .XX ±.010
 .XXX ±.005

DESIGNED	
DETAILED	
TRACED	
CHECKED	
APPROVED	MATHER, JD
ISSUED	

TITLE: Handle	
SCALE: 1:1	IPT:
COURSE:	SEC: IAM:
DATE: 1/1/2015	IDW: Scissors Jack S2015.idw

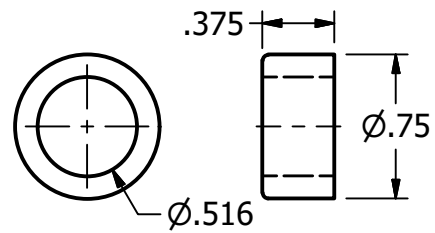
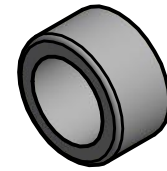

UNLESS OTHERWISE NOTED
 BREAK ALL SHARP EDGES .015
 STAMP DWG NUMBER ON ALL
 PARTS

TOLERANCE: ANGLES:
 .X ±.015 ±0.5
 .XX ±.010
 .XXX ±.005

DESIGNED	
DETAILED	
TRACED	
CHECKED	
APPROVED	MATHER, JD
ISSUED	

TITLE:		Screw Clearance Washer	
SCALE: 1:1	IPT:		
COURSE:	SEC:	IAM:	
DATE: 1/1/2015	IDW: Scissors Jack S2015.idw		

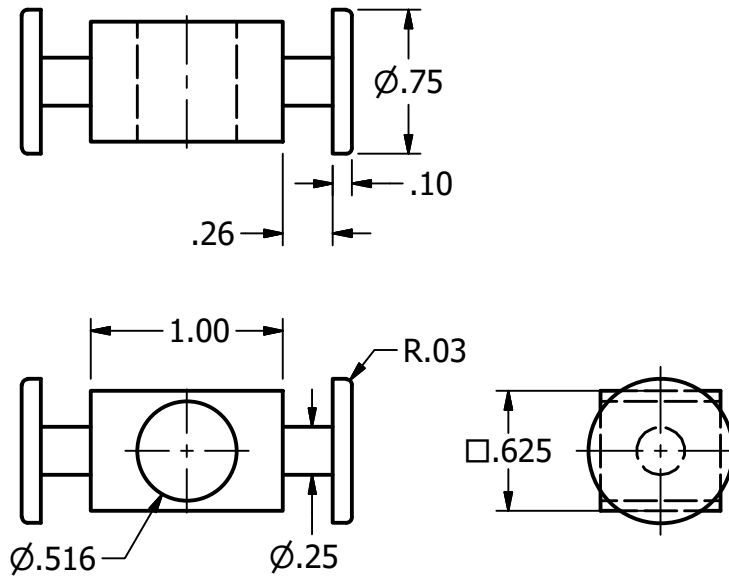
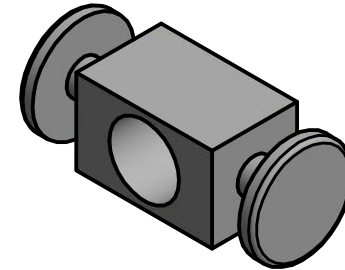

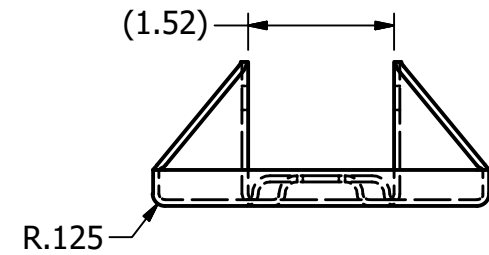
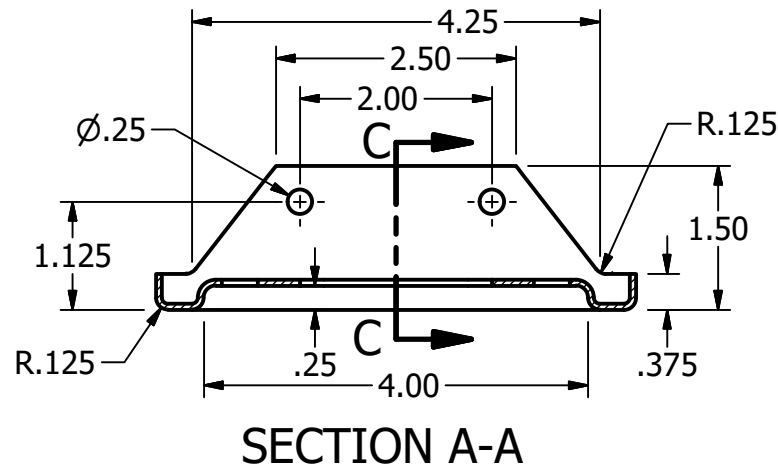
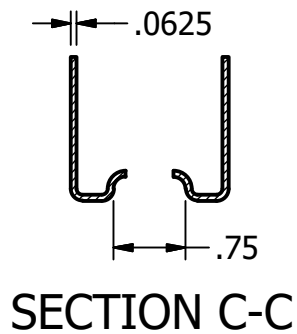
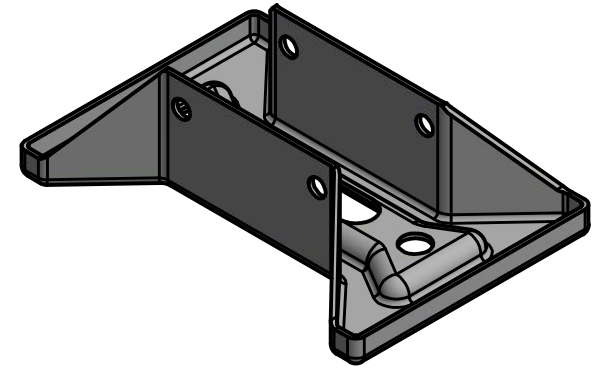
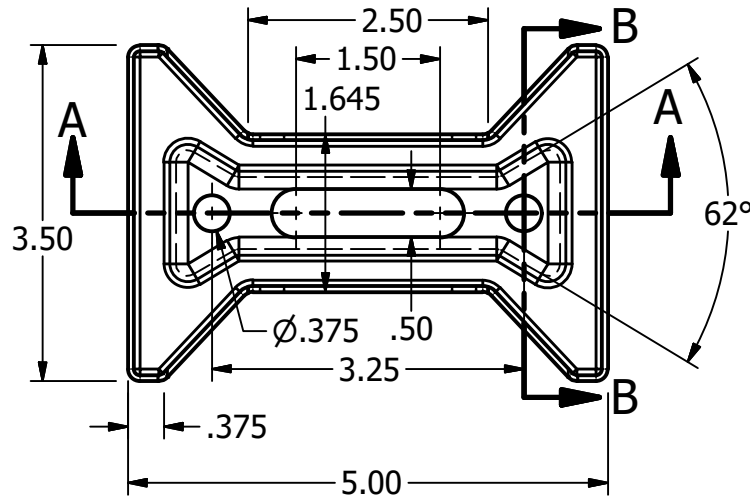
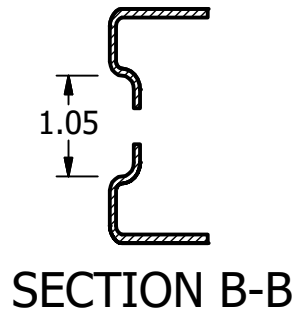

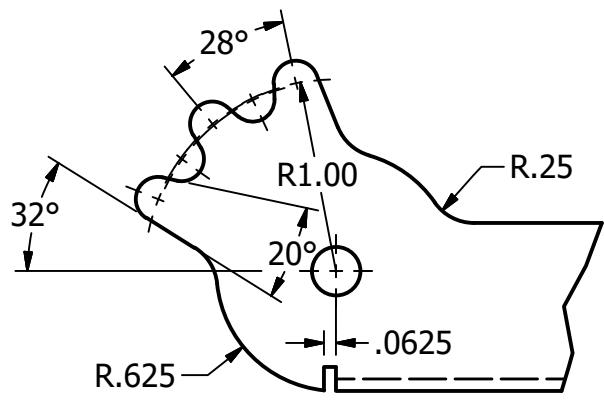
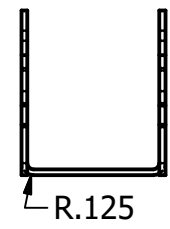
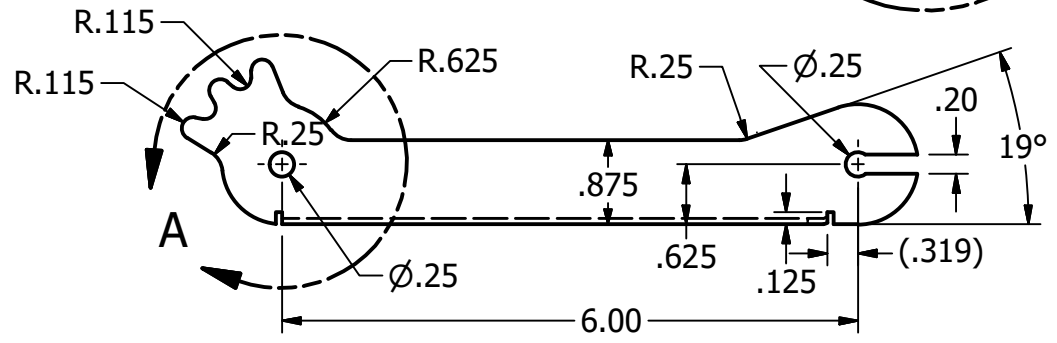
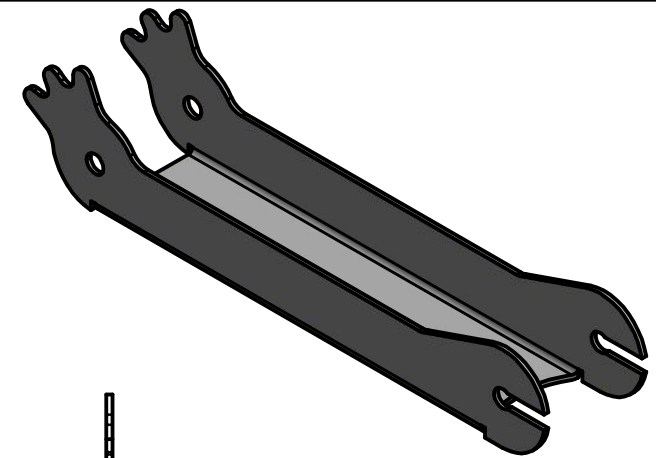
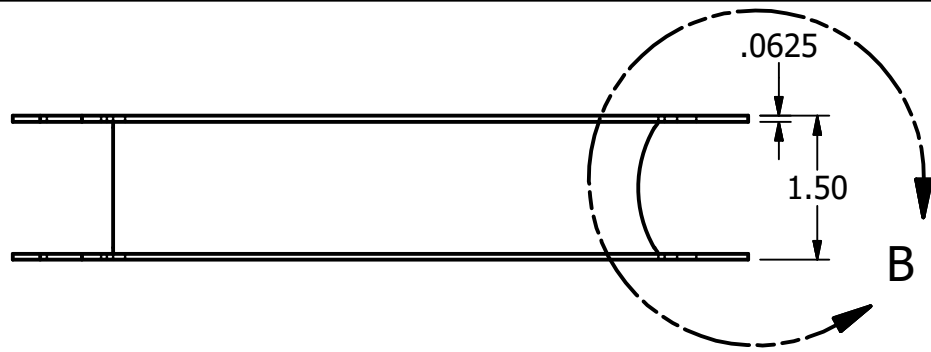

DETAIL A

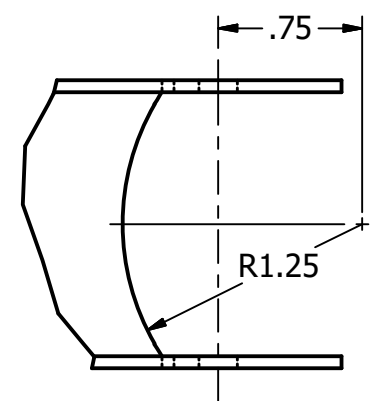

DETAIL B

UNLESS OTHERWISE NOTED
 BREAK ALL SHARP EDGES .015
 STAMP DWG NUMBER ON ALL
 PARTS
 TOLERANCE: ANGLES:
 .X ±.015 ±0.5
 .XX ±.010
 .XXX ±.005

DESIGNED	
DETAILED	
TRACED	
CHECKED	
APPROVED	MATHER, JD
ISSUED	

TITLE: Lower Left Arm	
SCALE: 1:2	IPT:
COURSE:	SEC: IAM:
DATE: 1/1/2015	IDW: Scissors Jack S2015.idw

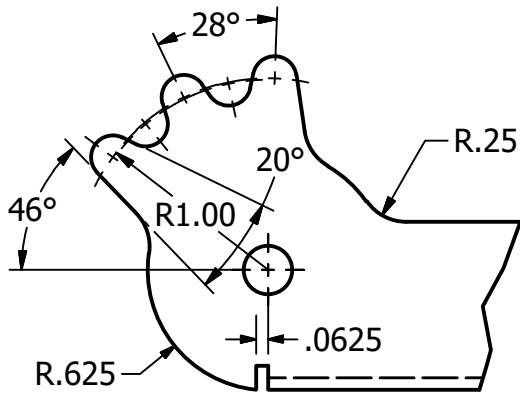
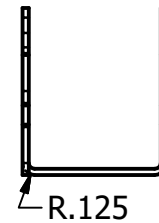
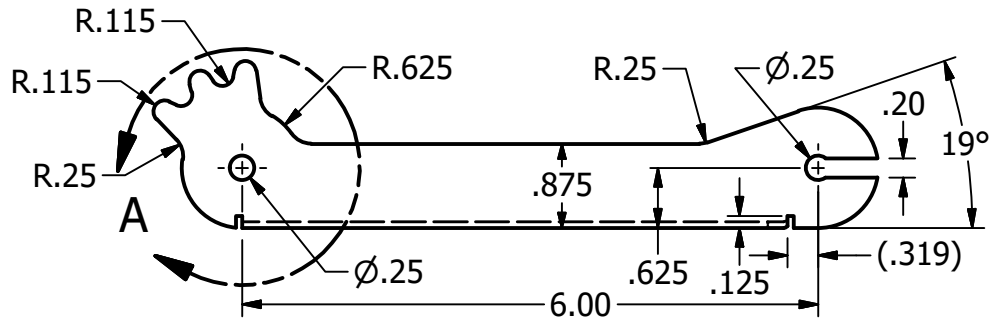
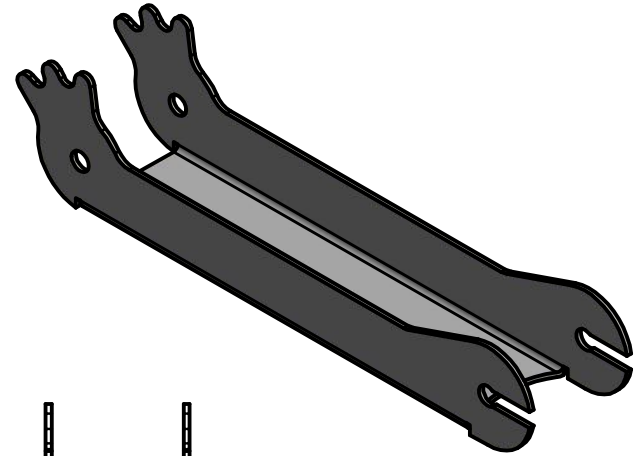
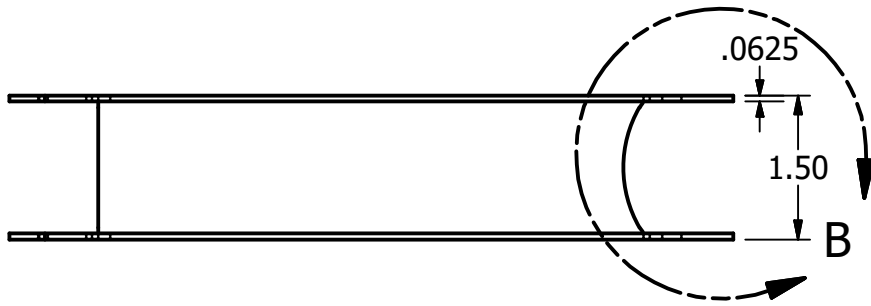

DETAIL A

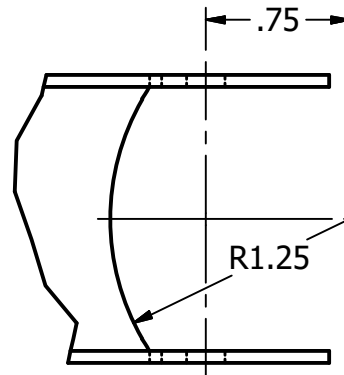

DETAIL B

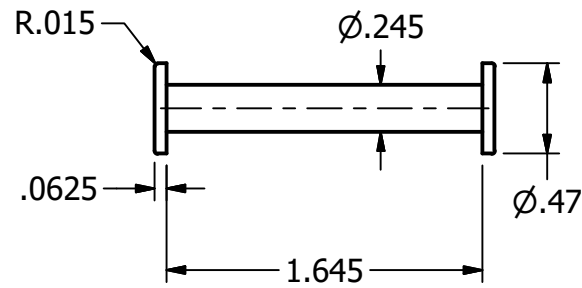
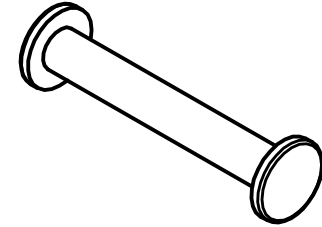

UNLESS OTHERWISE NOTED
 BREAK ALL SHARP EDGES .015
 STAMP DWG NUMBER ON ALL
 PARTS

TOLERANCE: ANGLES:
 .X ±.015 ±0.5
 .XX ±.010
 .XXX ±.005

DESIGNED	
DETAILED	
TRACED	
CHECKED	
APPROVED	MATHER, JD
ISSUED	

TITLE: Lower Rivet			
SCALE: 1:1		IPT:	
COURSE:	SEC:	IAM:	
DATE: 1/1/2015	IDW: Scissors Jack S2015.idw		

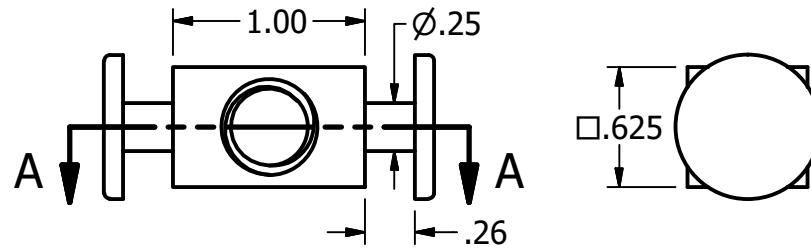
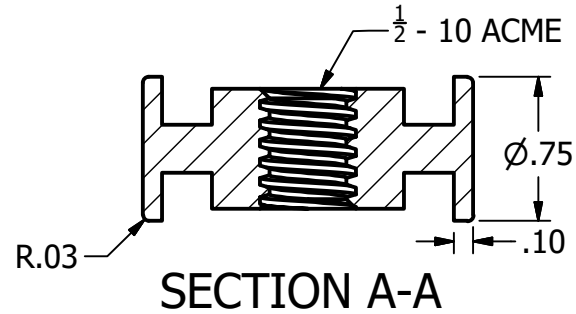
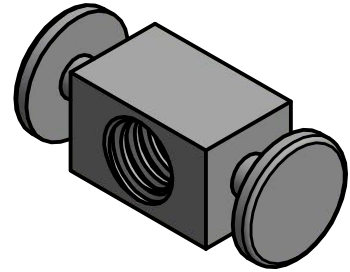

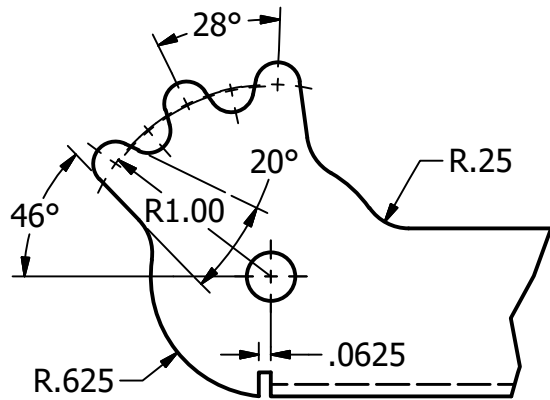
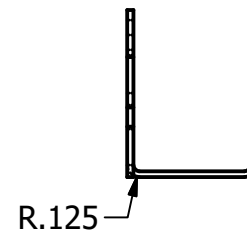
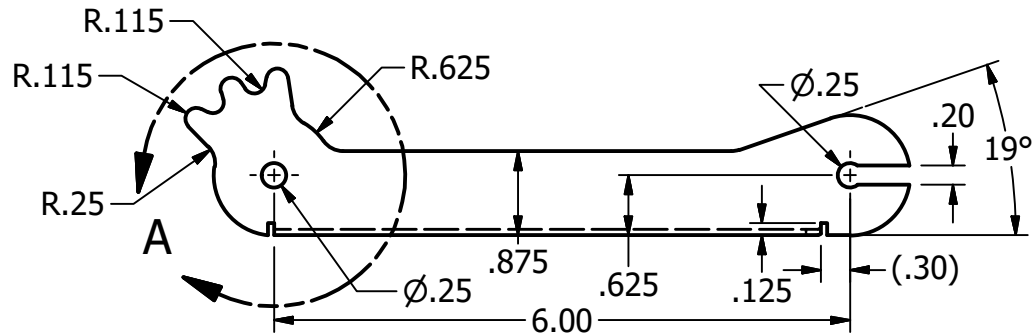
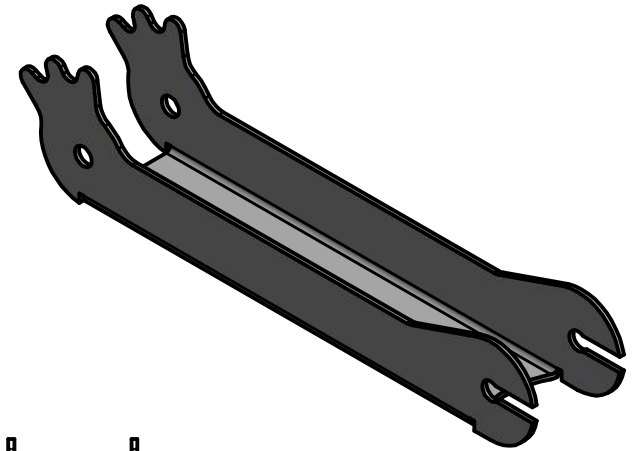
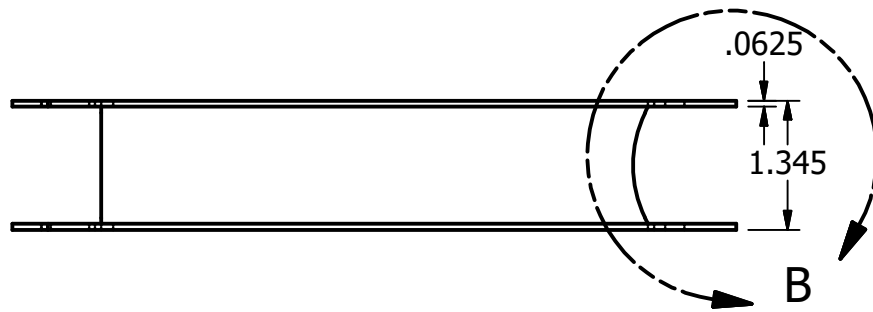

DETAIL A

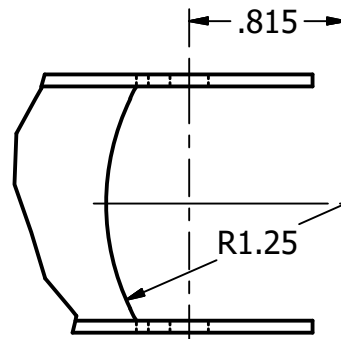

DETAIL B

UNLESS OTHERWISE NOTED
 BREAK ALL SHARP EDGES .015
 STAMP DWG NUMBER ON ALL
 PARTS

TOLERANCE: ANGLES:
 .X ±.015 ±0.5
 .XX ±.010
 .XXX ±.005

DESIGNED	
DETAILED	
TRACED	
CHECKED	
APPROVED	MATHER, JD
ISSUED	

TITLE:

Upper Left Arm

SCALE: 1:2

COURSE:

DATE: 1/1/2015

IPT:

SEC:

IDW: Scissors Jack S2015.idw

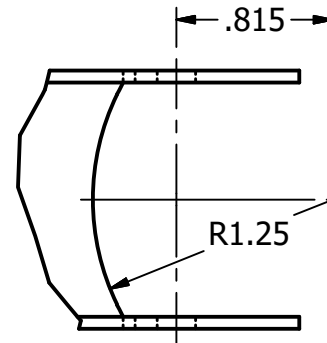
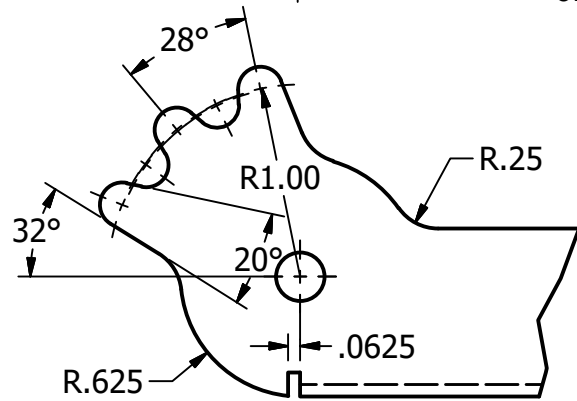
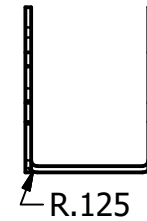
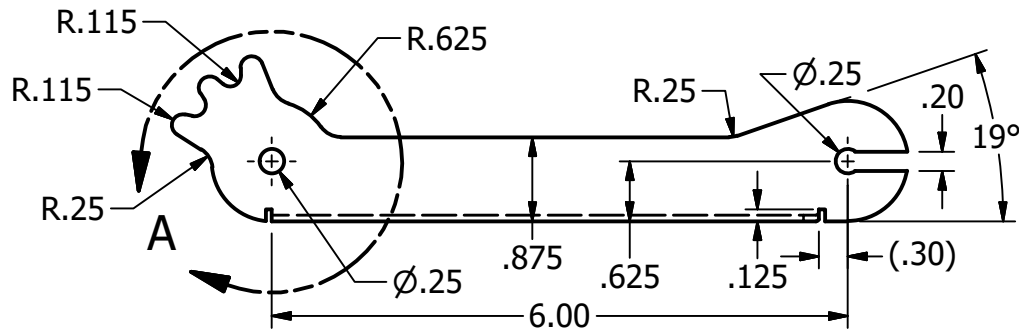
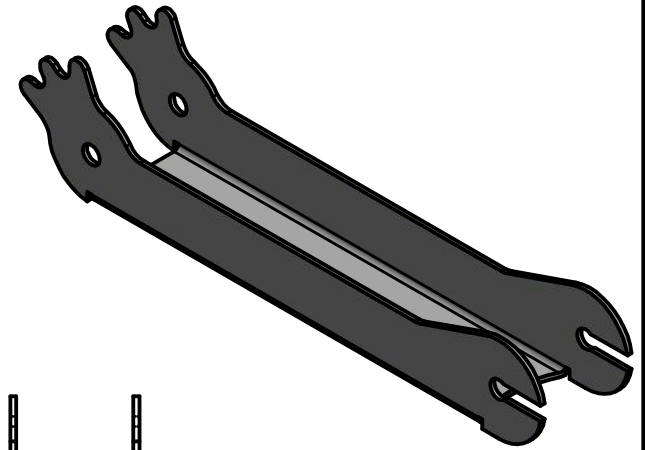
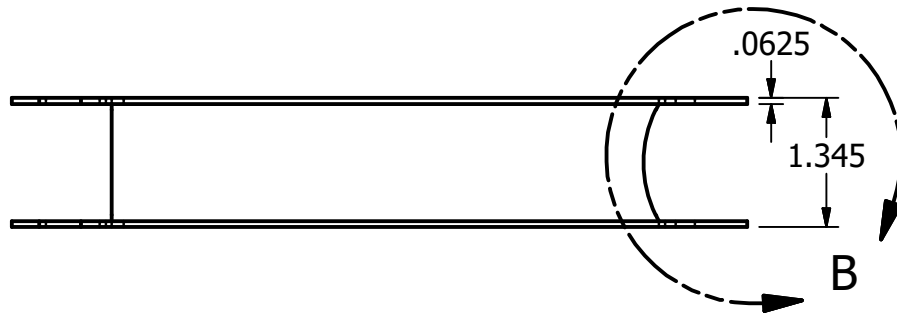

DETAIL A

DETAIL B

UNLESS OTHERWISE NOTED
 BREAK ALL SHARP EDGES .015
 STAMP DWG NUMBER ON ALL
 PARTS

TOLERANCE: ANGLES:
 .X ±.015 ±0.5
 .XX ±.010
 .XXX ±.005

DESIGNED	
DETAILED	
TRACED	
CHECKED	
APPROVED	MATHER, JD
ISSUED	

TITLE:

Upper Right Arm

SCALE: 1:2

COURSE:

DATE: 1/1/2015

IPT:

SEC:

IDW: Scissors Jack S2015.idw

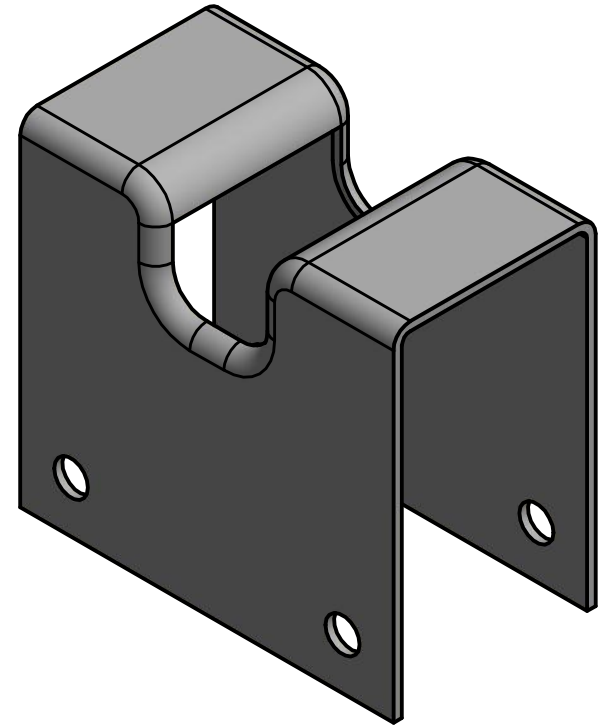
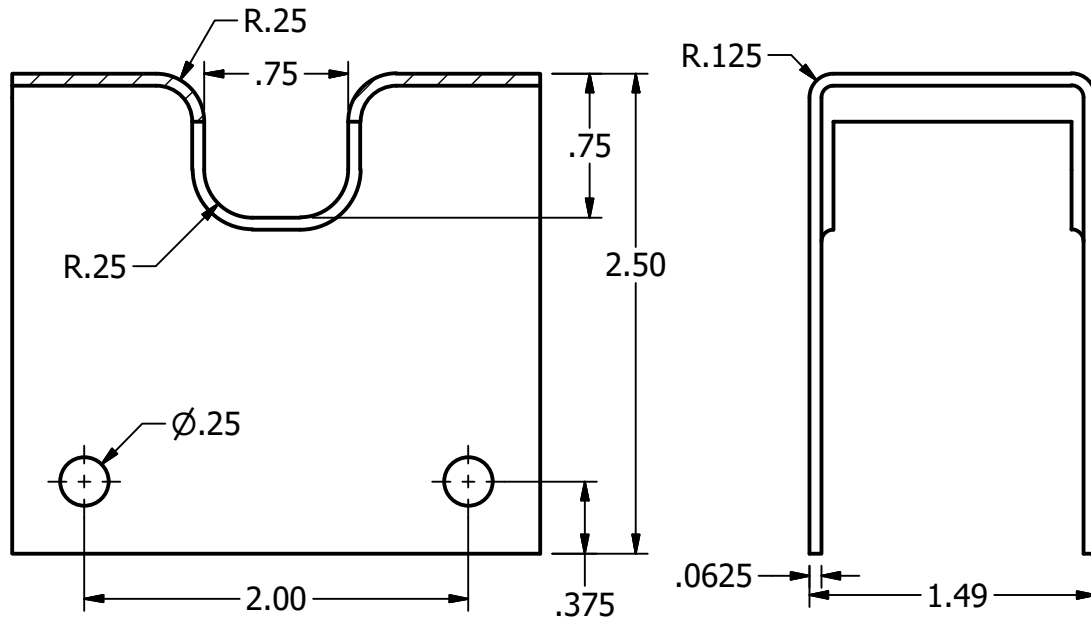
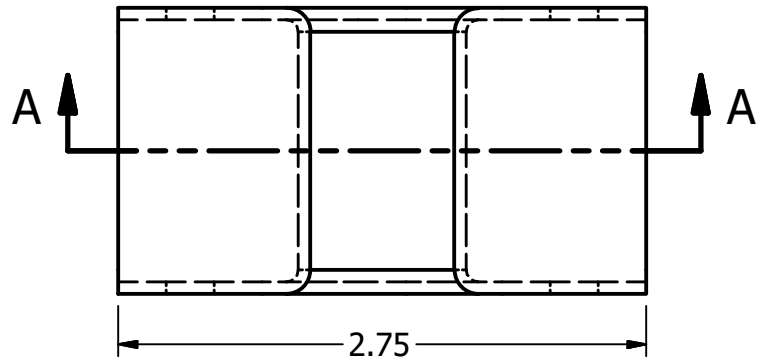

SECTION A-A

UNLESS OTHERWISE NOTED
 BREAK ALL SHARP EDGES .015
 STAMP DWG NUMBER ON ALL
 PARTS
 TOLERANCE: ANGLES:
 .X ±.015 ±0.5
 .XX ±.010
 .XXX ±.005

DESIGNED	
DETAILED	
TRACED	
CHECKED	
APPROVED	MATHER, JD
ISSUED	

TITLE: Lift Plate	
SCALE: 1:1	IPT:
COURSE:	SEC: IAM:
DATE: 1/1/2015	IDW: Scissors Jack S2015.idw

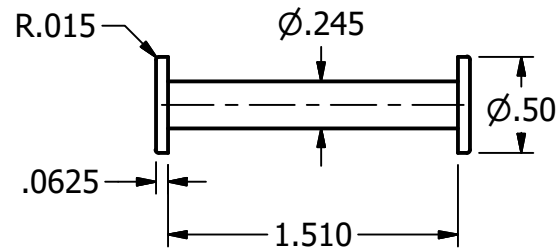
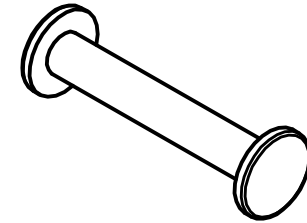

UNLESS OTHERWISE NOTED
 BREAK ALL SHARP EDGES .015
 STAMP DWG NUMBER ON ALL
 PARTS

TOLERANCE: ANGLES:
 .X ±.015 ±0.5
 .XX ±.010
 .XXX ±.005

DESIGNED	
DETAILED	
TRACED	
CHECKED	
APPROVED	MATHER, JD
ISSUED	

TITLE: Upper Rivet			
SCALE: 1:1		IPT:	
COURSE:	SEC:	IAM:	
DATE: 1/1/2015	IDW: Scissors Jack S2015.idw		